

SILENCE
FEELING
WHISPER
SPECTRA

room-sealed built-in gas-fireplace

installation guide and user manual

“Log Burner Technology”

 **faber**

Saturnus 8 NL-8448 CC Heerenveen
Postbus 219 NL-8440 AE Heerenveen
T. +31(0)513 656500
F. +31(0)513 656501



40 010 521
02 07

 **faber**

CONTENTS

1.	INTRODUCTION	2
2.	SAFETY INSTRUCTIONS	3
3.	INSTALLATION REQUIREMENTS	5
	3.1 Builders opening and surround	5
	3.2 Requirements outlet and exhaust	8
4.	INSTALLATION-INSTRUCTIONS	16
	4.1 Gas connection	16
	4.2 Preparation of the appliance	16
	4.3 Fitting the firebox	19
	4.4 Placing of the wood set	20
5.	INSTALLATION OF THE FLUE	22
	5.1 Connection of the flue	22
	5.2 Placing through existing chimney	23
	5.3 Remote control	25
6.	COMMISSIONING	27
	6.1 Check pilot ignition	27
	6.2 Functional burner check	27
	6.3 Functional balanced flue check	28
	6.2 Check reference pressure	28
7.	HANDING OVER	29
8.	SERVICING	30
	8.1 Routine annual servicing	30
	USER GUIDE	38
9.	SAFETY INSTRUCTIONS FOR THE USER	39
10.	CONTROLLING THE APPLIANCE	41
11.	CLEANING AND SERVICE INSTRUCTIONS	47
12.	DISPOSAL OF THE PACKAGING AND THE APPLIANCE	48
INDEX 1	LIST OF SPARE PARTS	35
INDEX 2	TECHNICAL DATA	36

1. INTRODUCTION

Note: these instructions should be read carefully and retained for future reference.

Please leave these instructions with the user.

This guide is concerning the following types of appliances:

Widescreen interior : Types Silence and Feeling
MV100 interior: Types Whisper and Spectra

Special features:

- Realistic flame and glow effect because of the "Log burner" technology.
- Room sealed room appliance, inlet and outlet are led to the outside using a natural draught concentric pipe system (100 mm/150 mm) (no power fan required). No additional ventilation required.
- Air supply and flue-gases go to outside atmosphere through wall or roof. A maximum horizontal extension of 6 meters is possible.
- Remote Control option on all appliances.
- Meets the essential requirements of the European Gas Appliance Directive (GAD) and carries the CE mark.

2. SAFETY AND GENERAL INFORMATION

Before installation, ensure that the local distribution conditions (identification of the type of gas and pressure) and the adjustment of the appliance are compatible.

This gas appliance is factory set and shall not be adjusted by the installer.

This appliance does not contain any component manufactured from asbestos or any asbestos related products.

The pilot and flame sensing device fitted to this fire is also a safety device. If for any reason any part of the pilot assembly is to be replaced the entire assembly including the pilot burner, thermocouple, electrode and injector must be exchanged complete for a pilot assembly from the original manufacturer only.

Ventilation

This appliance is room-sealed and doesn't require purpose provided ventilation.

2.1 General safety

It is the law in the UK that **all** gas appliances, are installed by a competent person in accordance with the Gas Safety (Installation and Use) Regulations (as amended), the relevant British Standards for Installation work, Building Regulations, Codes of Practice and the manufacturers instructions.

The installation should also be carried out in accordance with the following where relevant:

BS5871 Part1 BS5440 Parts 1 & 2 BS1251.

Building Regulations Document J (as applicable).

3. INSTALLATION REQUIREMENTS

Building Regulations and Standards issued as relevant by the Department of the Environment or the Scottish Development Department.

In the Republic of Ireland installation should be carried out in accordance with IS813, ICP3, IS327, Building Regulations, Codes of Practice, the manufacturers instructions and any other rules in force.

Failure to comply with the above could leave the installer liable to prosecution and invalidate the appliance warranty.

Safety instructions for the user: see chapter 9.

Note:

Since the appliance is a source of heat, circulation of air occurs. Therefore it is of importance that you do not use the appliance shortly after a renovation of the home. Because of the natural circulation of air, moist and volatile components from paint, building materials, carpet etc. will be attracted. These components can settle themselves down onto cold surfaces in the form of soot.

As on all heat producing appliances, soft furnishings such as blown vinyl wallpaper placed too near to the appliance may become scorched or discoloured. This should be born in mind when installing the appliance.

3.1 Builders opening and surround

The appliance can be installed in the following situations:

In a non-combustible fireplace or builders opening. This could be either an existing builders opening or a new made prefab builders opening. For the measurements, see figure 1 and index.

Although the appliance is tested for installation without a hearth, the appliance must not stand on combustible materials or carpets. If the appliance is placed on a combustible floor then a fibrelux or similar heatproof board of 12 mm thickness should be placed under it. Any under floor vents or openings within the builders opening should be sealed off.

Do not place the lintel, surround or marble stone directly onto the appliance. If possible, apply a lintel made of cement or something similar.

Isolate the appliance with a ceramic blanket (25 mm). See also chapter 4: Installation instructions.

Preferred choice for insulation is unbound insulation wool (at 1000 °C gives no smell).

3.1 Builders opening and surround (continuing)

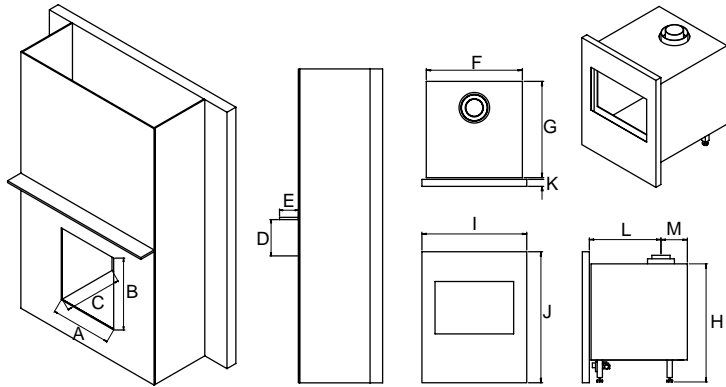

fig. 1

	Builders opening (mm)	Feeling	Silence	Whisper	Spectra
A	Opening width	960	960	780	780
B	Opening height	649	649	705	705
C	Opening depth (min.)	385	385	430	430
Shelf dimensions (combustible)					
D	Min. height shelf from top frame	350	350	350	350
E	Depth shelf max.	150	150	150	150
Dimensions (mm)					
F	Box width	880	880	750	750
G	Box depth	366	366	397	397
H	Box height	636	636	714	714
I	Frame width	1064	1064	815	790
J	Frame height	678	678	720	720
K	Frame thickness	47	20	16	22
L	Position flue (behind frame)	255	255	257	257
M	Position flue (from the back side box)	111	111	140	140

table 1

If the builders' opening is constructed out of non-combustible composition board (FibreLux) and you install the appliance without a mantel then:

- Ventilate the space above the appliance (min. 1000 mm²).
- Always fit the DC convection set.
- The plaster of the outside has to be resistant to a high temperature. Use therefore the plaster materials especially made for this, to prevent discoloring (min. 100 °C temperature resistant).

If the appliance is to be fitted against a wall with combustible cladding, the cladding must be removed from the area covered by the surround.

The minimum height from the top surface of the fire to the underside of any shelf made from wood or other combustible materials is as follows:

- For a shelf up to 150 mm deep – Minimum height = 350 mm (fig. 1).
- If the shelf depth is greater than 150 mm add 50 mm to the upper-clearance height for every 25 mm increase in shelf depth.
- Side clearance = Minimum distance from the side of the fire frame to combustible material = 150 mm.

3.2 Flue requirements

The appliance is of the type C11/C31. The appliance will need to be supplied with the approved flue pipes and terminal, it is not possible to supply your own.

The minimum effective height of the flue system must be 1 m.

Terminal locations, through the wall as well as through the roof. See figure 3.

Flue routing;

- a horizontal extension with elbows is allowed for a maximum of 6 meter (depending on the type and situation).
- vertical max. 12 meter.

Determine on the base of the table 2 and 3, depending on the type and terminal position, if the desired situation is possible.

To establish this you will need to calculate:

- The effective height (this is the real difference in height between the upper side of the appliance and the terminal).
- The total horizontal extension. This is the total horizontal flue length where:
 - each elbow, which is in the horizontal area, counts for 2 meters.
 - each 45-degree bend, which is in the horizontal area, counts for 1 meter.
 - elbows and bends at the transition of horizontal to vertically are not to be counted.
 - the wall mounted terminal counts for 1 meter.

Flue restrictor

If applicable, in the table is also stated the size of a flue restrictor. This restrictor needs to be fitted in the combustion chamber when placing the appliance (see chapter 4.2). Normally the smallest flue restrictor is fitted.

Example calculation 1

Calculation horizontal extension fig. 2a:

Flue lenght C + E = 1m + 1m 2 m
 Elbows D = 2m 2 m

Total horizontal extension 4 m

Measure or calculate effective height (Hvert)

Flue lenght A 1 m
 Roof mounted terminal 1 m

Total effective height 2 m

When calculating on basis of the Widescreen table Nr. 2:
 It is allowed.

When calculating on basis of the MV100 table Nr. 3:
 Allowed but without flue restrictor.
 Remove the flue restrictor!

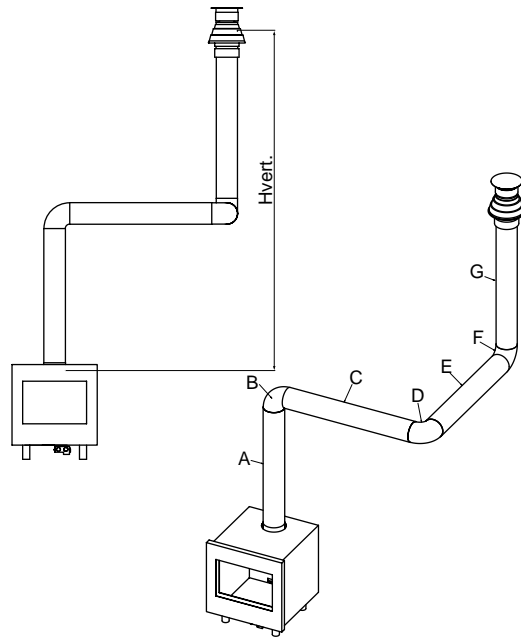

fig. 2a

Example calculation 2

Calculation horizontal extension fig. 2b:

Flue lenght J + L = 0,5 + 0,5 1 m
 Elbows K + M = 2m + 2m 4 m
 Terminal 1 m

Total horizontal extension 6 m

Vertical

Flue lenght H 1 m

When calculating on basis of the Widescreen table Nr. 2:
 It is allowed.

When calculating on basis of the MV100 table Nr. 3:
 Combination not allowed.

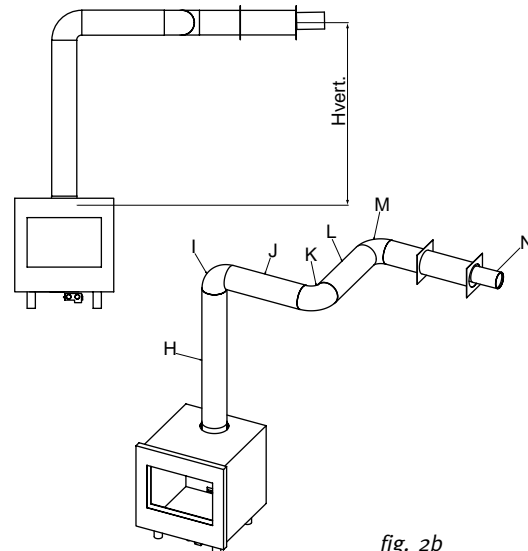

fig. 2b

Table Silence and Feeling with interior Widescreen

Determine according to the table 2 the right total horizontal- and vertical length. When meeting an X, and when the values are outside the table, the combination is not allowed. **Normally the 30 mm flue restrictor is preinstalled.**

Effective height	Horizontal extension						
	0	1	2	3	4	5	6
0	X	X	X	X	X	X	X
1	0	0	X	X	X	X	X
1,5	0	0	0	0	X	X	X
2	30	30	0	0	0	0	0
3	45	45	30	30	0	0	0
4	45	45	30	30	30	0	0
5	50	50	45	30	30	30	0
6	50	50	45	30	30	30	0
7	60	60	50	45	45	30	X
8	60	60	60	50	50	X	X
9	65	65	60	60	X	X	X
10	65	65	65	X	X	X	X
11	65	65	X	X	X	X	X
12	65	X	X	X	X	X	X

X combination not allowed
 0 remove flue restrictor
 30 mm flue restrictor
 45 mm flue restrictor
 50 mm flue restrictor
 60 mm flue restrictor
 65 mm flue restrictor

table 2

Table Whisper and Spectra with interior MV100

Determine according to the table 3 the right total horizontal- and vertical length. When meeting an X, and when the values are outside the table, the combination is not allowed. **Normally the 30 mm flue restrictor is preinstalled.**

Effective height	Horizontal extension						
	0	1	2	3	4	5	6
0	X	X	X	X	X	X	X
1	30	0	0	0	0	0	0/X*
2	30	30	0	0	0	0	0
3	45	45	30	0	0	0	0
4	45	45	30	0	0	0	0
5	50	50	45	45	30	0	0
6	50	50	45	45	30	0	0
7	60	60	60	50	50	45	X
8	60	60	60	60	50	X	X
9	65	65	60	60	X	X	X
10	65	65	65	X	X	X	X
11	65	65	X	X	X	X	X
12	65	X	X	X	X	X	X

X combination not allowed
 0 remove flue restrictor
 30 mm flue restrictor
 45 mm flue restrictor
 50 mm flue restrictor
 60 mm flue restrictor
 65 mm flue restrictor

* at propane not allowed

table 3

3.2 Flue requirements (continuing)

3.2.1 Terminal position

Verify if the required terminal position meets the local installation regulations regarding disturbance, good functioning and ventilation. (Also see: safety requirements).

Note:

The terminal must be located so that the outlet is not obstructed. If the flue terminal is located within 2 meters of a footway, path or where people could come into contact with it then a suitable terminal guard must be fitted.

Terminals located close to shared walkways, footpaths etc. could be subject to legal constraints and this should be pointed out to the customer before installation. If in any doubt about flue location advice should be sought from local building control, or if appliance-related, from the manufacturer including wherever possible a dimensioned sketch.

Avoid locating the terminal in close proximity to plastic materials such as gutters or other combustibles. If this is unavoidable then a suitable deflector should be made.

Some important requirements for a good functioning are:

The wall-mounted terminal has to be at a distance of at least 0,5 meters off:

- Corners of the building.
- Below eaves.
- Balcony's etc. unless the duct is dragged to the front side of the overhanging part.

The roof mounted terminal has to be at a distance of at least 0,5 meters of the sides of the roof, excluded the ridge.

Flue terminal positions

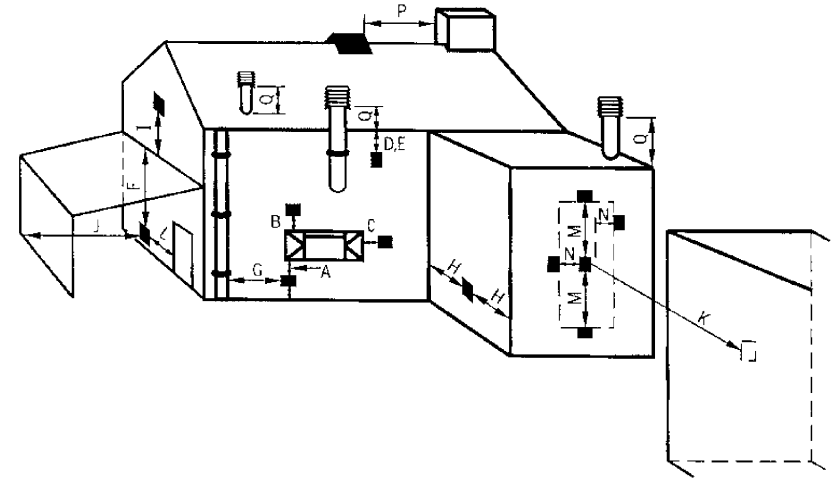

Flue terminal positions

fig. 3

Table 4

Dimension	Terminal position (kW input 0-7 kW expressed in net)	Balanced flue room sealed Natural draught
A	Direct below an opening, airbrick, opening windows, etc.	300 mm
B	Above an opening, airbrick, opening window ect.	300 mm
C	Horizontally to an opening, airbrick, opening window etc.	300 mm
D	Below gutters, soil pipes or drain pipes	500 mm
E	Below eaves	500 mm
F	Below balconies or car port roof	600 mm
G	From a vertical drain pipe or soil pipe	300 mm
H	From an internal or external corner	600 mm
I	Above ground roof or balcony level	300 mm
J	From a surface facing the terminal	600 mm
K	From a terminal facing the terminal	600 mm
L	From an opening in the carport (e.g. window) into the dwelling	1200 mm
M	Vertically from a terminal on the same wall	1500 mm
N	Horizontally from a terminal on the same wall	300 mm
P	From a vertical structure on the roof	600 mm
Q	Above intersection with roof	500 mm

Example of how terminal position is measured

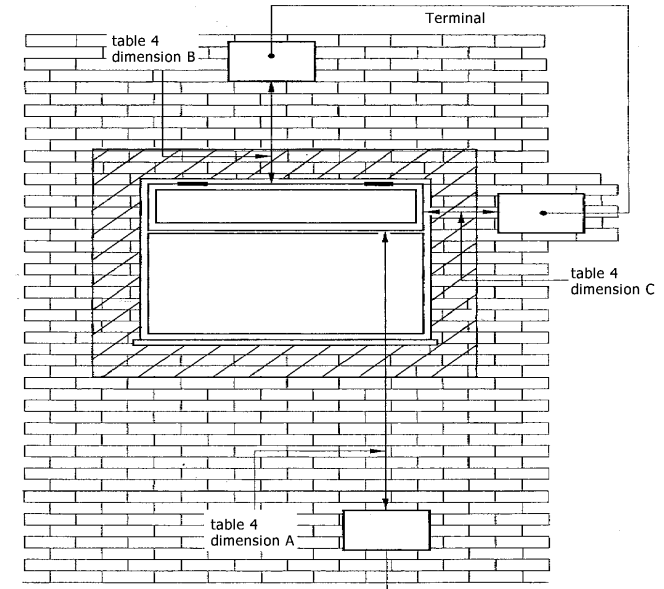

fig. 4

3.2.2 Using an existing chimney as air inlet

You can connect the appliance onto an existing chimney. The existing chimney then functions as air supply, where a flexible stainless steel liner (to BS715) of 100 mm performs the flue function.

Requirements:

- Any existing chimney used as an air supply must only service this appliance.
- A chimney that has previously been used for solid fuel must be swept before use.
- The existing chimney needs to be airtight.
- The existing chimney needs to have an opening of min. 150 x 150 mm.
- The chimney needs to be intact and well looked after.
- Use the adjustable roof-mounted-terminal especially made for this, and the chimney connection set.
- The minimum distance between two terminals should be at least 450 mm.

4. INSTRUCTIONS FOR INSTALLATION

4.1 Gas connection

1. Installation pipes should be in accordance with BS 6891. Pipe work from the meter to the appliance must be of adequate size.
2. The complete installation including the meter must be tested for soundness and purged as described in the above code.
3. A means of isolation must be provided in the supply to facilitate servicing.
4. The connection should be made in 8 mm copper or similar semi flexible tube. (max 1 meter). Ensure that the gas pipe does not interfere with the removal or replacement of the burner tray of the controls.
5. The gas connection is nut and olive suitable for 8 mm pipe.

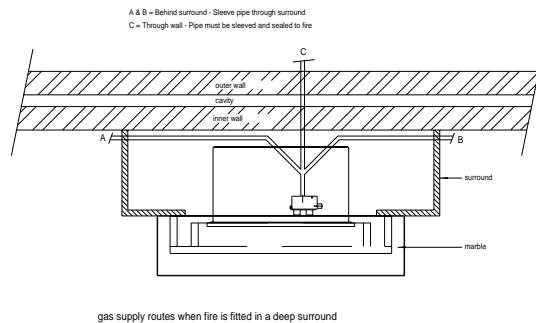

4.2 Preparing the appliance

1. Remove the front by loosening the screws A behind the door (see fig. 5). Lift and pull forward when you take it away.

4.2 Preparing the appliance (continuing)

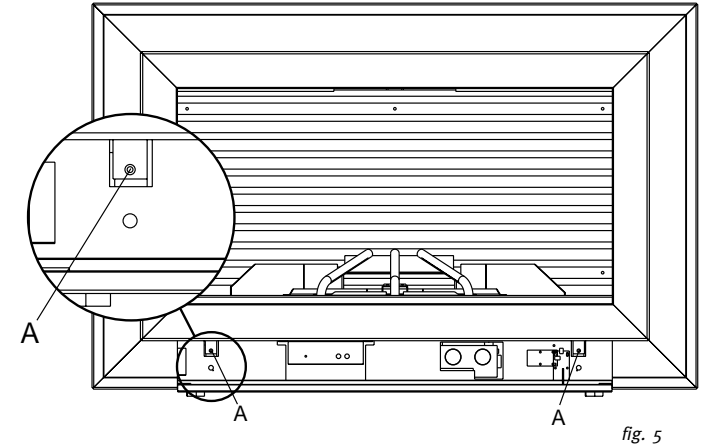

2. Remove the back panel by loosening the screws B (see fig. 6)

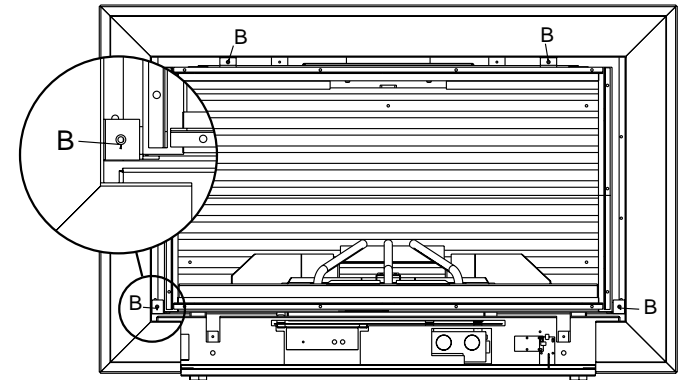

3. Remove the glass by removing the glass clamps C (see fig. 7) for instance with a screwdriver. Careful when removing the glass! Wear gloves! Before placing the glass back, be sure that there are no fingerprints on the glass, it is not possible to remove those prints after you burn the appliance or a while (they will be burnt in).

4.2 Preparing the appliance (continuing)

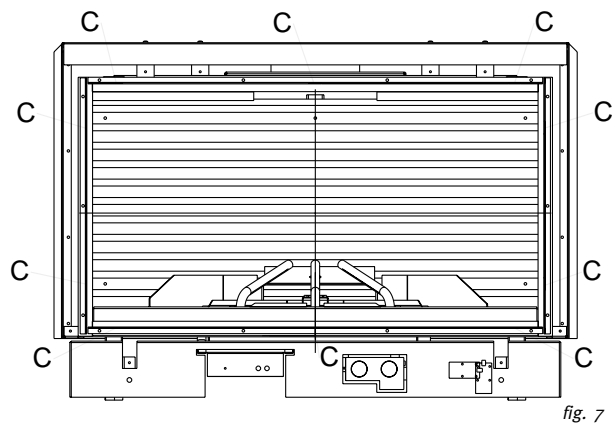

4. Take the box with the log set out of the combustion chamber.
5. Place the right flue restrictor in the combustion chamber. To determine the right flue restrictor, see chapter 3.

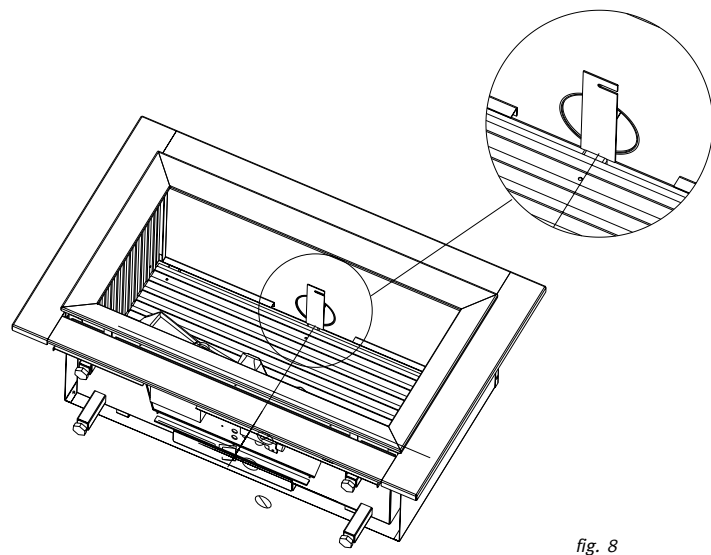

4.3 Fitting the firebox

Points of attention for placement:

- If possible, first locate the appliance before assembling the flue.
- If this is not possible then always use an extendible pipe before connection onto the appliance.

1. Position the firebox in the fireplace opening. You can adjust the height with the 4 adjustable feet.
2. Make the gas connection according to the instructions (also see gas connection, chapter 4.1).
3. Assemble the flue system onto the firebox (see chapter 5).
4. If necessary, place the DC convection system (also consult the instruction belonging to the DC construction set).
5. Isolate the firebox with a ceramic blanket (25 mm). Preferred choice for insulation is unbound insulation wool (at 1000 °C gives no smell).

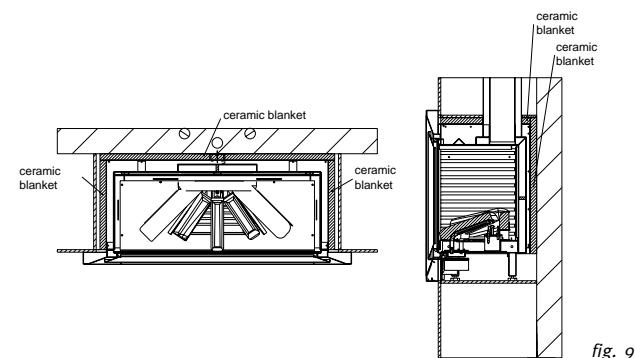

6. Place the log set (see placing log set, chapter 4.4).

4.3 Fitting the firebox (continuing)

7. Spread, the bags of embers (imitation ashes) provide with the appliance over the burner tray. **Attention!** No embers on the grid.
8. Before placing the glass; check the glass sealing rope is in good condition and makes an effective seal. Be sure that there are no fingerprints on the glass. It is not possible to remove those prints after you burn the appliance for a while (they are burnt in). Place the glass in front of the appliance and fix the glass frame or use the glass clamps.
9. Replace the front and fix it.

4.4 Placing the log set

The logs contain Refractory Ceramic Fibre which when cut or broken open can be an irritant to skin and the respiratory tract. Always wear gloves, do not blow dust into air and clean up using a vacuum cleaner equipped with a HEPA filter.

Never place extra elements of any kind into the combustion chamber. To guarantee good combustion, the log set may only be installed in the way specified by Faber International. Any other arrangement can lead to soot on logs or window. Do not use the fire with broken or missing logs.

4.4 Placing the log set (continuing)*fig. 10*

On the bottom of the logs is a identification:

- L location on the left side resting on the rear log.
- R location on the right side resting on the rear log.
- 1 dimple first log left placed over the burner and resting on the burner tray.
- 2 dimples placed in the middle over he burner and resting on the burner tray.
- 3 dimpels the right side log placed over the burner and resting on the burner tray.

5. INSTALLATION OF THE FLUE

5.1 Connections with use of concentric duct material

- Build the system starting from the appliance on.
- Make a hole of \varnothing 153 mm for the wall or roof mounted terminal.
- Make sure you place the pipes in the right direction, the narrow end towards the appliance.
- Make sure the pipes are fixed sufficiently, a wall clamp every 2m, so the weight of the pipes is not resting onto the appliance.
- The outside of the pipe can become hot (140 degrees). Stay 50 mm away from wall surface or sealing. Make sure to provide sufficiently heat resistant isolation when going through the wall or roof.
- Because of expansion or cooling down the concentric pipes can turn loose. It is recommended to fix the spring clip with a self tapping screw at inaccessible places.
- To get the exact measure flue length you can use cut down-concentric pipe, wall mounted terminal or roof mounted terminal. To obtain a smoke sealed connection, the inner pipe must be 20 mm longer than the outside pipe.
- The horizontal pipes need to rise away from the appliance at a rate of 3 degrees per metre.

5.2 Connection onto an existing chimney

You can connect the appliance onto an existing chimney. The existing chimney then functions as air supply, where a flexible stainless steel liner (to BS715) of 100 mm performs the flue function. Any existing chimney used as an air supply must only service this appliance.

Requirements:

- 300 mm of free space above the appliance;
- The chimney only supply's air to this appliance;
- The existing chimney needs to be clean and very well swept;
- The existing chimney needs to be airtight;
- The existing chimney needs to have an opening of min. 150 x 150 mm.

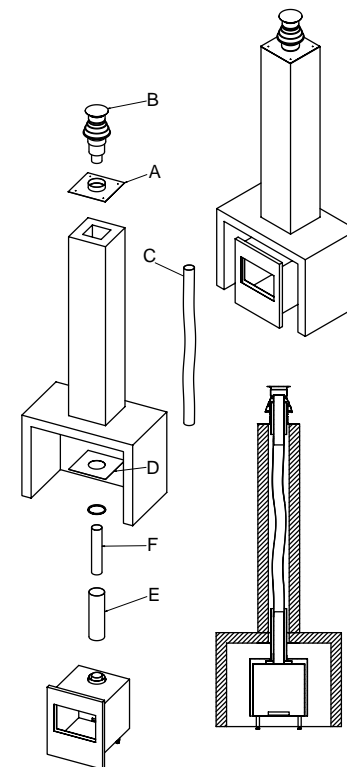

1. Place the aluminium closure plate (A) onto the chimney. Permanently attach and make airtight.
2. Cut down the roof mounted terminal (B) to the required length. At least cut off 500 mm. Leave the inner pipe at least 100 mm longer than the outside pipe. You need the cut off pieces for connection of the appliance.
3. Pull the liner (C) through the chimney.
4. Connect the liner onto the roof terminal and fix this with the clamp provided with the chimney connection set.
5. Place the roof terminal onto the closure plate.
6. Fixing the chimney sealing plate (D) and place the 150 mm grommet into the hole of the sealing plate.

fig. 11

5.2 Connection onto an existing chimney (continuing)

7. Fix the sealing plate air tight into the builders opening (use the isolation rope from the chimney connection set to make the plate air tight).
8. Slide the cut off outside pipe (E) into the sealing plate. Slide this pipe so far that you will have enough space later on for assembling the liner.
9. Install the appliance.
10. Connect the flexible stainless steel liner onto the appliance using the cut off 100 mm inner pipe (F) as adapter.
11. If the distance from the flue outlet to the sealing plate is bigger than 300 mm, you have to use a concentric pipe first.
12. Slide the outside pipe onto the appliance or concentric extension so that you have a air tight connection.

5.3 Remote control (if applicable)

The remote control is only meant to regulate the flames, it functions only when the pilot burner is ignited. It is therefore not possible to ignited the appliance with the remote control or to shut-off the pilot-flame.

The radio-frequency remote control is intended for fireplaces installed in a domestic setting in all EU countries except Austria, Denmark, Finland, Greece, Portugal and Spain.

Features:

- Manual control will always remain possible.
- The remote control is a radio frequency type and has been approved internationally.
- The remote control generates a unique safety code every time you activate the transmitter, its similar to those used in a car.
- The remote control is easy to install retrospectively.

5.3.1 Installation remote control

1. Connect the mains adapter to the receiver box. The adapter is set to the correct voltage in the factory 4.5V.

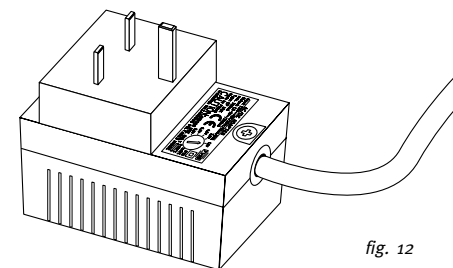
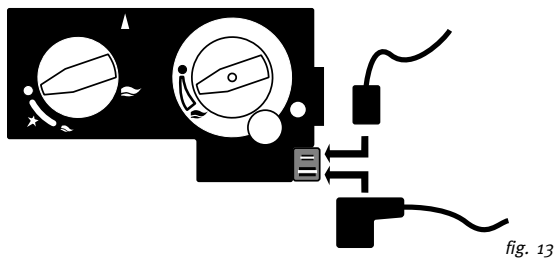

fig. 12

2. Slide the receiver box into the holder.

3. Connect the wires to the gas valve (see fig. 13).



4. Check that there are batteries in the transmitter. See "Replacing batteries", see chapter 10.4.4.
5. Set the on/off switch on the receiver to "on".

Setting the right transmission code

The receiver has to learn the code from the transmitter, which is already done at the factory. However the code disappears if the receiver is disconnected from the mains for a longer period, or when you use the transmitter out of the range of the receiver for more than 15 times. The code then doesn't match the code in the receiver.

1. Push the "mod" button on the receiver and hold it for 3 seconds.
2. The green control lamp will light up and stay on. Repeat this step if it doesn't.
3. Push a button on the remote control. The control lamp on the receiver should now go out.
4. Again push a button on the remote control. The lamp starts flashing and will switch off eventually.
5. The receiver now recognizes the remote control. The remote control now functions.
6. Check if you can hear a sound and the motor runs when you push a button on the remote control.

6. COMMISSIONING (functional checks)

6.1. Check pilot ignition

1. Push in and turn the control knob (A) from ● anticlockwise to the setting 🔥 (small flame). You will hear a tick meaning there is ignition. Hold the knob in and wait for a few seconds while the air is purged.
2. Bring the knob back in the start position and turn the knob several times to the 🔥 position. Check that the pilot has lit.
3. Continue to hold in the control knob for a further ten seconds to ensure that the pilot flame is stable.
4. Release the knob. The pilot should remain alight.

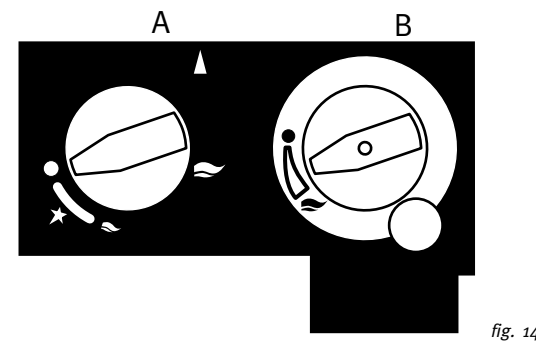

6.2 Functional burner check

1. Turn knob (B) to max. clockwise.
2. Turn the knob (A) more anticlockwise to the 🔥 position (large flame). Now it is possible to light the main burner.
3. Turn knob B anticlockwise to max. The main burner should light. Check for gas soundness at all joints with leak detection fluid!
4. Check the ignition of the main burner on low and high setting.
5. Turn knob B clockwise till ●. The main burner is off.
6. Turn the knob A to ●. The pilot should go out.

6.3 Functional balanced flue check

1. Set the appliance on max. input.
2. Verify the flame picture, this means no flames against the window, the flame have to come besides the logs, if not check the log layout.
3. Check if the flames are yellow after 10 minutes of operation. If you still have a blue flame or the appliance goes out check:
 - If the flue pipes are fitted correctly (no leakage).
 - If the wall mounted terminal is placed with the correct side up.
 - If the correct flue restrictor is installed.

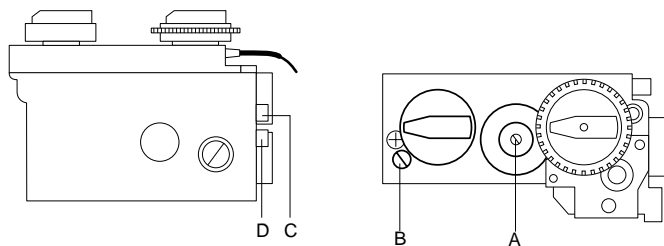

fig. 15

6.4 Check reference pressure

The appliance is preset to give the correct heat input. No further adjustment is necessary. Fit a pressure gauge at the test point D to check the burner pressure.

The pressure should be checked with the appliance alight and at max input.

The **cold** setting pressure should be as shown at the technical data page 36.

After checking the pressure, turn off the appliance. Remove the pressure gauge and close the sealing screw. Re-light the appliance. Turn to max. input and test around the test point D for gas soundness using a suitable leak detection fluid.

7. HANDING OVER

(final check and customer briefing)

- 7.1 Instruct the customer on the full operation of the appliance.
- 7.2.1 Advise the customer how to clean the appliance including the glass.
- 7.2.2 Instruct the customer on the operation of the remote control, including replacement of batteries and how to set the right transmissions code.
- 7.2.3 Hand over these instructions including the user guide to the consumer.
- 7.2.4 Recommend that the appliance should be serviced by a competent person at least once a year.

8. SERVICING

To ensure safe, efficient operation of the appliance, it is necessary to carry out routine servicing at regular intervals.

It is recommended, that the fire is inspected/serviced by a competent person at least once a year.

Important

Turn off the gas supply before commencing any servicing. Always test for gas soundness after refitting the appliance.

8.1 Routine annual servicing

1. Clean (if necessary):
 - the pilot system;
 - the burner;
 - the combustion chamber;
 - the glass.
2. Check the log lay and replace the embers (if applicable).
3. Do the functional test as described at page 27.
4. Check the flue system and terminal on damage and soundness (visual inspection).

Note

The logs contain Refractory Ceramic Fibre which when cut or broken open can be an irritant to skin and the respiratory tract. Always wear gloves, do not blow dust into air and clean up using a vacuum cleaner equipped with a HEPA filter. Never place extra elements of any kind into the combustion chamber. To guarantee good combustion, the log set may only be installed in the way specified by Faber International. Any other arrangement can lead to soot on logs or window. Do not use the fire with broken or missing logs.

8.1.1 Cleaning the glass

Depending on the intensity of use, you can get a deposit on the glass. This can be removed with a special ceramic glass cleaner (ceramic cook-top cleaner) as follows:

1. Remove the front and the back.
2. Clean the glass. Handle the glass with clean hands, wear gloves if possible.
3. To fit the glass, proceed in reverse order. Make sure that the log set has been installed correctly before fixing the glass.

Attention:

Before placing the glass: check the glass sealing rope is in good condition and makes an effective seal. Be sure that there are no fingerprints on the glass. It is not possible to remove those prints after you burn the appliance for a while (they are burnt in). Place the glass in front of the appliance and fix the glass frame or use the glass clamps.

8.1.2 Cleaning the combustion chamber and burner

You can clean the combustion chamber with a vacuum cleaner **excluding the burner surface.**

If the burner is visibly damaged, this can affect the distribution of the flame, if so then replace the burner.

8.1.3 Propane conversion

For conversion from propane to natural gas, order for a propane burner unit.

Please give the serial number from the data plate when you order.

8.1.4 Burner tray assembly

1. Remove the front, glass, log set, grid and burner tray cover.
2. Break the gas supply at the control valve.
3. Unscrew the burner assembly and take them out of the combustion chamber.

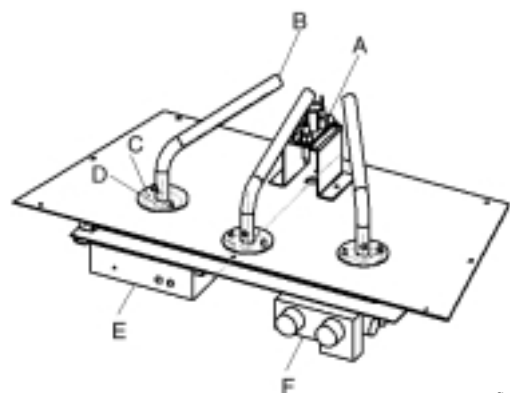

fig. 16

- A. Pilot assembly
- B. Burner
- C. Fixation plate
- D. Injector
- E. Receiver
- F. Gas control

8.1.5 Pilot/thermocouple assembly

Remove the burner tray as described above.
Now you have access to all the pilot and thermocouple parts.

8.1.6 Gas control block

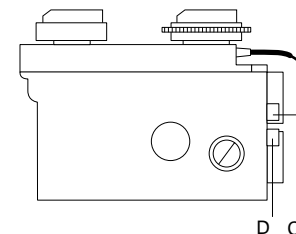

- A Governor
- B Adjusting screw pilot flame
- C Inlet pressure test point
- D Burner pressure test point

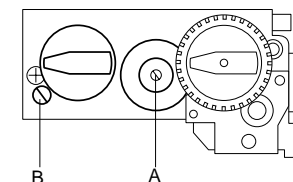

fig. 17

8.1.7 Combustion test

A BS7967 combustion analysis check should be carried out using an analyser to BS7927 positioned in the flue outlet.

A Ratio of CO/CO₂ should be less than 0.01 within 30 minutes.
(100ppm CO per 1% CO₂).

A reading of CO in the room centre should give a rise of less than 9ppm over ambient, peak reading.

INDEX 1 LIST OF SPARE PARTS

	Whisper/Spectra	Feeling	Silence
Description	Company part	Company part	Company part
Surround antracite	A9271453	A9270053	A9267753
Glas	04508200	04508300	04508300
Burner NG	20521808	20521808	20521808
Burner propane	20521835	20521835	20521835
Log set	20773200	20774500	20752500
Receiver	20604000	20604000	20604000
Remote control	20603900	20603900	20603900
Adapter	20900142	20900142	20900142
Gas control	37003089	37003089	37003089
Motor (remote control)	37003086	37003086	37003086
Spark wire	06017300	06017300	06017300
Spark electrode	06006600	06006600	06006600
Pilot burner assembly NG	20900145	20900145	20900145
Thermocouple	37002033	37002033	37002033
Pilot burner assembly propane	20900154	20900154	20900154
Embers	20900019	20900019	20900019
Heat resisting paint spray for combustion chamber	09000008	09000008	09000008
Set of glass clips	20900008	20900008	20900008
Touch Latch assembly	28103900	28103900	28103900

INDEX 2 TECHNICAL DATA

Country		UK/IRL	UK/IRL	UK/IRL	UK/IRL
Category		II2H3+	II2H3+	II2H3+	II2H3+
Appliance		Silence/Feeling	Silence/Feeling	Whisper/Spectra	Whisper/Spectra
Model type		C11 / C31	C11 / C31	C11 / C31	C11 / C31
Type of gas		G20	G30	G20	G30
Heat input Hi	kW	7.5	7.2	7.5	7.5
Efficiency class		2	2	2	2
NOX class		4	4	4	4
Inlet pressure	mbar	20	30/37	20	30/37
Gas rate (15° C / 1013 mbar)	m ³ /h	0.74	0.22	0.74	0.23
	kg/h		0.57		0.58
Reference burner pressure	mbar	17	22	17	22
Injector size	mm	2 x 1.4 and 1 x 1.3	3 x 1.00	2 x 1.4 and 1 x 1.3	3 x 1.00
Reduced input restrictor	mm	1.8	1.1	1.8	1.1
Pilot assembly					
Type		SIT 160	SIT 160	SIT 160	SIT 160
Code		nr. 51	nr. 30	nr. 51	nr. 30
Flue system					
MV size		100-150	100-150	100-150	100-150
Preinstalled flue restrictor	mm	30	30	30	30
Cas control		GV36-C5AOEHC68M	GV36-C5AODHC68M	GV36-C5AOEHC68M	GV36-C5AODHC68M
Remote control					
Adapter		230 VAC/50Hz/5VA	230 VAC/50Hz/5VA	230 VAC/50Hz/5VA	230 VAC/50Hz/5VA
Voltage adapter		4.5V	4.5V	4.5V	4.5V
Batteries remote control		2 x LR03 1.5V Alkaline long life	2x LR03 1.5V Alkaline long life	2 x LR03 1.5V Alkaline long life	2 x LR03 1.5V Alkaline long life
Gas connection		8 mm nut and olive	8 mm nut and olive	8 mm nut and olive	8 mm nut and olive
Dimensions: see table 1					

USER GUIDE

9. SAFETY INSTRUCTIONS FOR THE USER

9.1 General safety instructions

If a gas leak is found or suspected, turn off the gas supply at the meter and contact your installer or gas emergency service.

These instructions should be read carefully and retained for future reference.

Do not use the fire with a broken or damaged glass.

The fire has a safety device which turns off the gas supply if there is a build up from flue gasses in the combustion room or a temporary gas cut-off. **Wait at least 5 minutes before turning the appliance on again.** Contact a qualified installer when the appliance goes off regularly.

The appliance has been designed for heating purposes. This means that all surfaces, including the glass, can become very warm (over 100 degrees). An exception to this is the lower side of the door and the control buttons.

Due to the newness of materials, they may give off a slight smell for a period after initial lighting. This is normal, odours will disperse after a few hours use.

Do not place curtains, clothing, laundry, furniture or other flammable materials nearby the appliance. The required minimum distance is 100 cm.

Switch off the receiver of the remote control if you don't use the fire for a long time. Do not let children use the remote control without supervision.

IMPORTANT

A suitable Fireguard conforming to BS6539 and BS6778 should be used with this appliance to protect children, the elderly or infirm. Care should also be taken with pets.

In your own interest and that of safety, all gas appliances must be installed by competent persons. Installation must be in accordance with National Regulations. CORGI registered installers are required to work to recognised standards.

Note:

Since the appliance is a source of heat, circulation of air occurs. Therefore it is of importance that you do not use the appliance shortly after a renovation of the home. Because of the natural circulation of air, moist and volatile components from paint, building materials, carpet etc. will be attracted. These components can settle themselves down onto cold surfaces in the form of soot. As on all heat producing appliances, soft furnishings such as blown vinyl wallpaper placed too near to the appliance may become scorched or discoloured. This should be born in mind when installing the appliance.

10. CONTROLLING THE APPLIANCE**10.1 Lighting the fire**

If the main burner or pilot light are extinguished for any reason, **do not attempt to relight the pilot within 5 minutes**. Contact a qualified installer when the appliance goes off regularly.

The control valve is behind the door .

With control button A you can light the pilot. With the control button B you can adjust the height of the flames (see fig. 18).

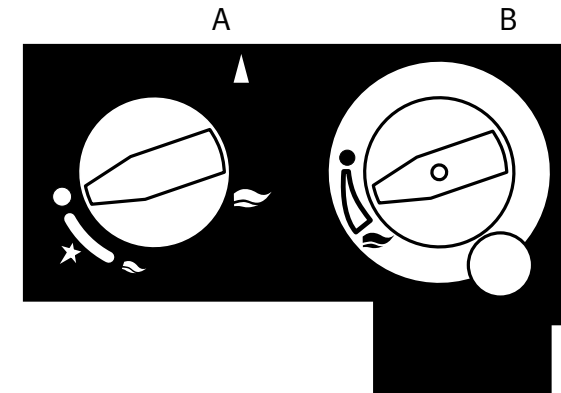

fig. 18 control unit

Knob A

The ● is the OFF position preventing any gas from passing through the control valve to either the pilot burner or to the main burner. By pressing the knob in it is possible to turn it anticlockwise. The first function is to turn on the gas to the pilot- this occurs just before reaching the ★ position (if the fire has not been lit for some time it may be necessary to hold the knob in this position for some seconds to clear the air from the pipe and allow gas to reach the pilot burner).

Once gas is available at the pilot, continued rotation anti-clockwise will cause the piezo igniter to spark. This is accompanied by a click at the valve and should result in the pilot burner igniting.

Once the pilot is lit, the control knob should be held pressed in for 10 seconds. In this time the pilot flame will have heated the flame supervision thermocouple sufficiently to operate a hold-on magnet within the valve.

Now turn the control knob A to the 🔥 position. This allows gas to enter control knob B.

Knob B

The ● is the OFF position preventing gas entering the main burner if the pilot is lit.

The knob should be turned slowly anticlockwise. This allows gas to enter the burner and be ignited by the pilot flame. Once ignition has taken place, the fire may be set to any level between min. and max. by adjusting the control knob B.

10.2 To light

1. Push in and turn the control knob (A) from ● anticlockwise to the setting 🔥 (small flame). You will hear a ignition click. Check that the pilot is lit (if not repeat).
2. Continue to hold in the control knob for a further ten seconds to ensure that the pilot flame is stable.
3. Release the knob. The pilot should remain alight.
4. Turn the control knob A to the 🔥 position.
5. Turn knob B slowly anticlockwise, the fire should then ignite.
6. Adjust flames to the required level.

10.3 To extinguish

1. For the main burner turn the control knob B clockwise to position ●.
2. To disable knob B turn knob A to the 🔥 position.
3. To extinguish the pilot turn control knob A to position ● , although it is in order to leave the pilot permanently lit.

10.3.1 When the pilot extinguishes

Warning! When the pilot extinguishes, for whatever reason, you should wait at least 5 minutes before trying to turn it on again.

Possible causes of pilot extinguish are:

- Operating error.
- Interference of the safety device.
- Failure in the pilot flame system.

Contact a qualified installer when the appliance goes off regularly.

10.4 Remote control version

The remote control is only meant to regulate the flames from off till max., it functions only when the pilot burner is ignited and knob A in 🔥 (big flame) position. It is therefore not possible to ignite the pilot flame with the remote control or to extinguish the pilot flame. The radio-frequency remote control is intended for fireplaces installed in a domestic setting in all EU countries except Austria, Denmark, Finland, Greece, Portugal and Spain.

Features:

- Manual control will always remain possible.
- The remote control is a radio frequency type and had been approved internationally.
- The remote control generates a unique safety code every time you activate the transmitter, its similar to those used in a car.
- The remote control is easy to install retrospectively.
- If you have no connection for the mains adapter, you can place batteries into the receiver. We advise to use the adapter because batteries have a very limited life (max 2 months).

10.4.1 To light

fig. 19

remote control

1. Push in and turn the control knob (A) from ● anticlockwise to the setting 🔥 (small flame). You will hear a ignition click. Check that the pilot is lit (if not repeat).
2. Continue to hold in the control knob for a further ten seconds to ensure that the pilot flame is stable.
3. Release the knob. The pilot should remain alight.
4. Turn the control knob A to the 🔥 position.
5. Set the on/off switch on the receiver to "on".
 - ↳ low flame
 - ↳ high flame
6. Use ↳ (high) and ↳ (low) to achieve the desired heating and flame effect.
7. You will hear a beep every time the receiver recognises a good signal. (If not, so see 10.4.3, setting the right transmission code).
8. When the fire is not be used for a prolonged period, turn off the pilot (see 10.4.2).

10.4.2 To extinguish

1. Push ↳ (low) till the burner goes out and you can hear the motor clicking.
2. To enable the remote control turn knob A to the 🔥 position.
3. To extinguish the pilot turn control knob A to position ●, although it is in order to leave the pilot permanently lit.

10.4.3 Setting the right transmission code

The receiver has to learn the code from the transmitter, which is already done at the factory. However the code disappears if the receiver is disconnected from the mains for a longer period, or when you using the transmitter for more then 15 times out of the range of the receiver (then the code doesn't match the code in the receiver).

1. Push the "mod" button on the receiver and hold it for 3 seconds.
2. The green control lamp will light up and stay on. Repeat this step if not.
3. Push a button on the remote control. The control lamp on the receiver should now go out.
4. Again push a button on the remote control. The lamp starts flashing and will switch off eventually.
5. The receiver now recognizes the remote control. The remote control now functions.
6. Check if you can hear a sound and the motor runs, when you push a button on the remote control. (If not so please check the batteries).

10.4.4 Changing the batteries

There is no risk of electric shock as the low voltage supply is similar to that used in torches. Always turn off the appliance before changing batteries.

Receiver if applicable

1. Open the door or the ashtray on the front side of the appliance. You will find the receiver, placed in a holder.
2. Take the receiver out the holder. (If necessary remove the two connectors from the control valve).

10.4.4 Changing the batteries (continuing)

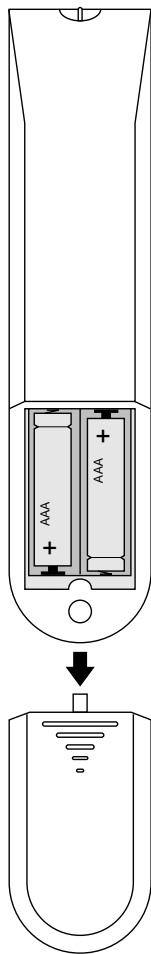

3. Remove the old batteries first and place the new ones: 4 x battery LR14 Alkaline long life 1.5 Volt. Pay attention to the + and - position.
4. Place the receiver back into the holder.
5. It might be possible that you have to set the transmission code after changing batteries (see 10.4.3).

Remote control

1. Remove the cover on the back of the remote control.
2. Carefully remove the battery clip along the side. Pay attention not to pull the wires.
3. If necessary, remove the old batteries and place the new ones: 2 x LR03 Alkaline long life 1.5 V. Pay attention to the + and - position.
4. Click the battery clip into the remote control and close the cover.
5. It might be possible that you have to set the transmission code after changing the batteries (see 10.4.3).

Note

Batteries are chemical waste and should be disposed in accordance with local regulations.

11. CLEANING AND SERVICE

INSTRUCTIONS

Important:

Turn off the fire and allow it to cool down before commencing cleaning.

It is recommended that the fire is inspected/serviced, by a competent person at least once a year.

To maintain the finish on the trim wipe with soft damp cloth only. Do not use abrasive cleaners, polish or solvents as these can damage the surface finish.

fig. 20

changing batteries

12. DISPOSAL OF THE PACKAGING AND THE APPLIANCE

The appliance packaging is recyclable. The packaging could include the following materials:

- cardboard;
- CFC-free foam (soft);
- wood;
- plastic;
- paper.

These materials should be disposed responsibly and in conformity with government regulations.

Batteries are considered chemical waste. The batteries should be disposed of responsibly and in conformity with government regulations. Remove the batteries before disposing of the remote control.

Information on how to responsibly dispose of discarded appliances can be obtained from the local authorities.